

## I Rugged Thermal/Full HD IP/ Pan/Tilt/Zoom Camera System

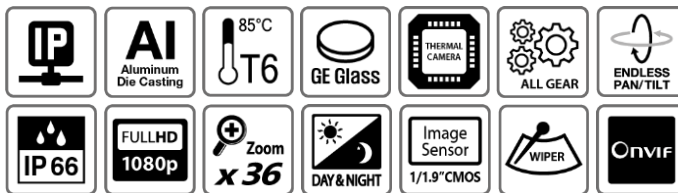

## iCUBE-PD-100

### Key Features

- 100% Gear Type Rotation Mechanism Structure
  - Excellent Durability, Ideal for Environments with Severe Vibration
- Built-in Intelligent Encoder and High-End Step Motor. Suitable for AI video surveillance
- Specialized powder coating optimized for coastal areas, ships, power plants, steel mills, cement factories, and other dust explosion zones.
- High Quality Aluminum Die-Casting Body
- Full HD 2 Megapixel, 1/1.9" High Sensitivity STARVIS CMOS Sensor
- Focal Length / Zoom : 6~216mm / Optical 36x & Digital 32x
- Equipped with high-performance hybrid infrared LED(MAX.50M)
- Ingress Protection Rating : IP66
- Pan / Tilt Range : 360° Endless / +90 ° ~ -90 ° (360° Endless\_Option)
- Pan / Tilt Speed : 0.025°~120°/sec
- 255 Preset / 8Tours / 8Groups / 8Swings
- Vox Uncooled FPA / 12μm Pixel Pitch, LWIR, 8 to 14μm
- 640 (h) × 512 (v) Pixel Lens, 19mm (22.9° X 18.4°)
- 384 (h) × 288 (v) Pixel Lens 13mm (28.4° X 21.4°)
- Thermal Sensitivity of Detector (NETD) ≤50mk@f#1.0
- Measurement Range : -20~+120°C (High 550°C), Accuracy ±2°C or 2% of ambient Temperature
- Support NOVIF

## THERMAL PART

Detector	Vox Uncooled FPA
IR Sensor Resolution	640 (h) × 512 (v) Pixel
Pixel Pitch	12 μm
Wavelength Band	LWIR, 8 to 14 μm
Lens (FoV)	19mm / 22.9°(H) × 18.4°(V) 13mm / 32.9°(H) × 22.9°(V)
Frame Rate	25Hz
Thermal Sensitivity of Detector (NETD)	≤50mk@f#1.0
Measuring Range	-20 ~ +120°C (High 550°C)
Accuracy	±2°C / 2% of ambient Temperature
Temperature Alarm	Highest Temperature Alarm
Temperature Alarm Range Setting	Yes
Temperature Dynamic Range Setting	Manual setting of upper/lower limit temperature color
Color Palette	Rainbow and 9 others
Highest Temperature Display	Yes
Temperature Compensation	Yes
Number of Concurrent Users	8 (RTSP Streaming)

## CAMERA PART

Sensor Type	1/1.9" Sony STARVIS CMOS Sensor
Effective Pixels	1937(H) × 1097(V)=2.12 M Pixels
Resolution	1920 × 1080p
Lens	F= 6mm~216mm / F1.5(wide) ~ F4.8(tele)
Angular Field of View (D/H/V)	D : 63.31°(W)~2.44°(T) / H : 56.5°(W)~2.12°(T) / V : 33.63°(W)~1.19°(T)
Zoom	Optical 36x & Digital 32x
Minimum Illumination	Color : 0.15 Lux / BW : 0.01lux / Color DSS(1/7.5s) : 0.0375lux / BW DSS(1/7.5s) : 0.002lux
Day & Night	Auto / Day / Night
White Balance	Auto / One Push / Manual / Indoor / Outdoor
Backlight Compensation (WDR)	Real-Time True WDR, Off / WDR / BLC / HLC
Function	Digital Image Stabilizer / Defog Function
DNR	Auto / Off / Low / Middle / High
Digital Slow Shutter	Off / 2x / 4x
Video Quality Adjustment	H.264 / H.265 / MJPEG
Streaming Capability	Primary : H.264 Secondary x3 : H.264 / MJPEG
Ethernet	Ethernet 10/100/1000base-T(RJ-45)
IP	IPv4 / IPv6
Protocol	TCP/IP, UDP/IP, RTP(UDP), RTP(TCP), RTCP, RTSP, NTP, HTTP, HTTPS, SSL, DHCP, PPPoE, FTP, SMTP, ICMP, IGMP, SNMPv1/v2/v3(MIB-2), ARP, DNS, DDNS
ONVIF	Yes

## MECHANICAL PART

Construction	High Quality Aluminium Diecasting Body, Power coating for vessel
Window	Tempered Glass, Germanium Glass, Protection Grid
IP Rate	IP66
Tilt Range	+90°/Sec_Endless_Option)
Pan Range	360°(Endless)
Pan/Tilt Speed	0.025~120°/sec (Basic 60°/sec)
Infrared	High Performance Hybrid Infrared LED Visible Distance up to 50 meters
Operating Temperature	-20°C~+55°C
Preset	255 Programmable Positions
Tour / Group / Swing	8 Programmable Positions
Communication Control	TCP/IP, RS-485
Supply Voltage	AC 24V, 50/60Hz
Power Consumption	Up to 100W
Wiper	Built-in
Cable Entry	3/4" NPT
Dimensions	475(W) x 232(H) x 365(L) mm
Weight	About 18 kg

## DIMENSION(mm)

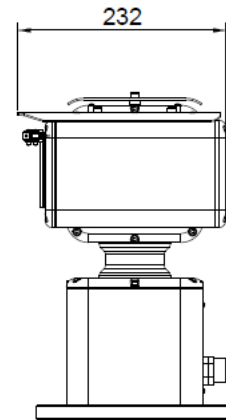
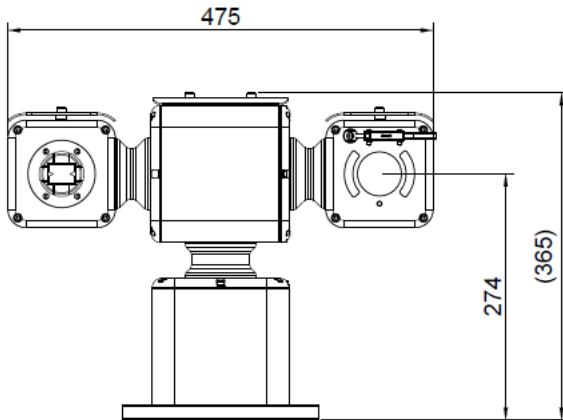

M20 Cablegland

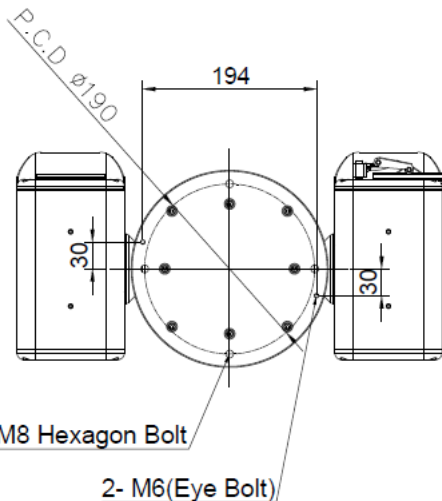

4 - M8 Hexagon Bolt

2- M6(Eye Bolt)

